



# Operator's Manual

## Rear-tine Tiller Models

630B—Tuffy®

634F—Bronco™

634B—Super Bronco™

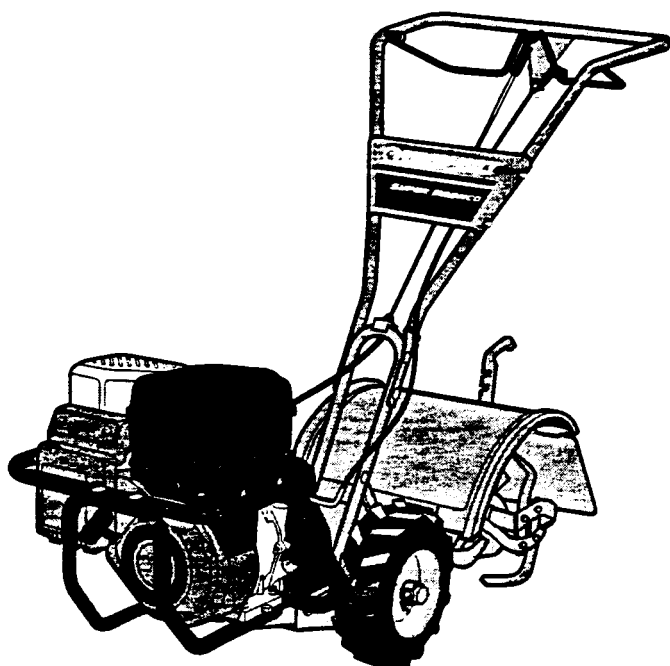

Model 634B Shown

### **IMPORTANT: READ SAFETY RULES AND INSTRUCTIONS CAREFULLY**

**Warning:** This unit is equipped with an internal combustion engine and should not be used on or near any unimproved forest-covered, brush-covered or grass-covered land unless the engine's exhaust system is equipped with a spark arrester meeting applicable local or state laws (if any). If a spark arrester is used, it should be maintained in effective working order by the operator. In the State of California the above is required by law (Section 4442 of the California Public Resources Code). Other states may have similar laws. Federal laws apply on federal lands. A spark arrester for the muffler is available by contacting the service department at Troy-Bilt LLC, P.O. Box 361131 Cleveland, Ohio 44136-0019.

**TROY-BILT LLC, P.O. BOX 361131, CLEVELAND, OH 44136-0019**

PRINTED IN USA

FROM NO. 770-10594A  
(12/2001)

## TABLE OF CONTENTS

Content	Page
Calling Customer Support .....	2
Safety .....	3
Assembly .....	6
Features and Controls .....	10
Operation .....	12
Maintenance .....	17
Off-Season Storage .....	21
Troubleshooting .....	22
Parts List .....	23
Warranty Information .....	Back Cover

### FINDING MODEL NUMBER

This Operator's Manual is an important part of your new Rear-tineTiller. It will help you assemble, prepare and maintain the unit for best performance. Please read and understand what it says.

Before you start assembling your new equipment, please locate the model plate on the equipment and copy the information from it in the space provided below. This information is very important if you need help from our Customer Support Department or an authorized dealer.

- You can locate the model number by looking at the rear surface of the tine shield. A sample model plate is explained below. For future reference, please copy the model number and the serial number of the equipment in the space below

 <p><b>TROY-BILT LLC</b> P. O. BOX 361131 CLEVELAND, OH 44136 <b>330-558-7220</b> <b>866-840-6483</b></p>	<p>Copy Model Number Here _____</p> <p>Copy Serial Number Here _____</p>
---	---

### ENGINE INFORMATION

The engine manufacturer is responsible for all engine-related issues with regards to performance, power-rating, specifications, warranty and service. Please refer to the engine manufacturer's Owner's/Operator's Manual packed separately with your unit for more information.

### CALLING CUSTOMER SUPPORT

If you have difficulty assembling this product or have any questions regarding the controls, operation or maintenance of this unit, please call the Customer Support Department.



Call 1- (330) 558-7220 or 1- (866) 840-6483 to reach a Customer Support representative. Please have your unit's model number and serial number ready when you call. See previous section to locate this information. You will be asked to enter the serial number in order to process your call ..

For more details about your unit, visit our website at [www.troybilt.com](http://www.troybilt.com)



This machine meets voluntary safety standard B71.8 – 1996, which is sponsored by the Outdoor Power Equipment Institute, Inc., and is published by the American National Standards Institute.

## WARNING

The engine exhaust from this product contains chemicals known to the State of California to cause cancer, birth defects or other reproductive harm.

### Safety Alert Symbol



This is a safety alert symbol. It is used in this manual and on the unit to alert you to potential hazards. When you see this symbol, read and obey the message that follows it. Failure to obey safety messages could result in personal injury or property damage.

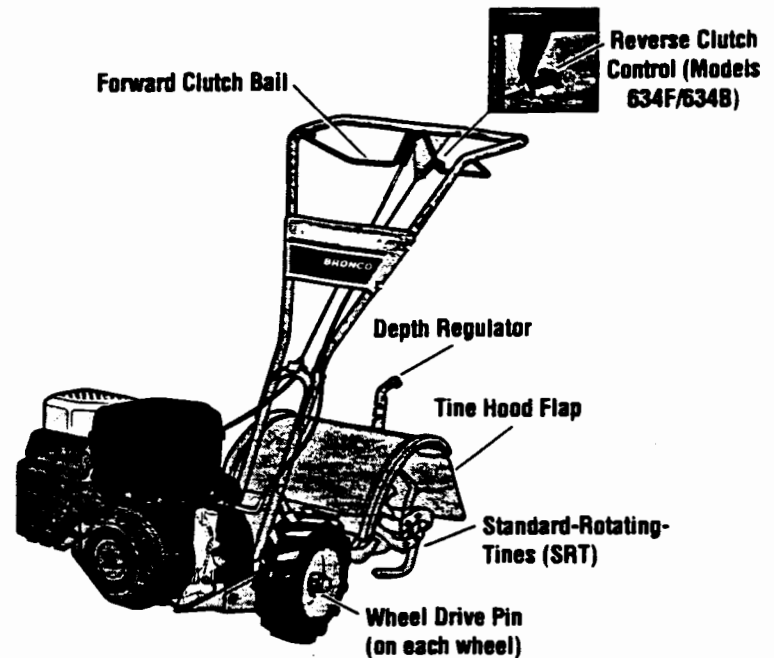

Figure 1-1: Tiller features and controls (5.5HP Model shown). See separate Engine Owner's Manual to identify engine controls.



### Training

1. Carefully read this Owner's Manual, the separate Engine Owner's Manual, and any other literature you may receive. Be thoroughly familiar with the controls and the proper use of the tiller and its engine. Know how to stop the unit and disengage the controls quickly.
2. Never allow children to operate the tiller. Never allow adults to operate the tiller without proper instruction.
3. Keep the area of operation clear of all persons, particularly children and pets.
4. Keep in mind that the operator or user is responsible for accidents or hazards occurring to other people, their property, and themselves.

### Preparation

1. Thoroughly inspect the area where the tiller is to be used and remove all foreign objects.
2. Be sure all tiller controls are released and both wheels are in the Wheel Drive position before starting the engine.
3. Do not operate the tiller without

wearing adequate outer garments. Avoid loose garments or jewelry that could get caught in moving parts.

4. Do not operate the tiller when barefoot or wearing sandals, sneakers, or light footwear. Wear protective footwear that will improve footing on slippery surfaces.
5. Do not till near underground electric cables, telephone lines, pipes or hoses. If in doubt, contact your telephone or utility company.
6. Warning: Handle fuel with care; it is highly flammable and its vapors are explosive. Take the following precautions:

- a. Store fuel in containers specifically designed for this purpose.
- b. The gas cap shall never be removed or fuel added while the engine is running. Allow the engine to cool for several minutes before adding fuel.
- c. Keep matches, cigarettes, cigars, pipes, open flames, and sparks away from the fuel tank and fuel container.
- d. Fill fuel tank outdoors with extreme care. Never fill fuel tank indoors. Use a funnel or spout to prevent spillage.

- e. Replace all fuel tank and container caps securely.
- f. If fuel is spilled, do not attempt to start the engine, but move the machine away from the area of spillage and avoid creating any source of ignition until fuel vapors have dissipated.

7. Never make adjustments when engine is running (unless recommended by manufacturer).

### Operation

1. Do not put hands or feet near or under rotating parts.
2. Exercise extreme caution when on or crossing gravel drives, walks, or roads. Stay alert for hidden hazards or traffic. Do not carry passengers.
3. After striking a foreign object, stop the engine, remove the wire from the spark plug wire and prevent it from touching the spark plug. Thoroughly inspect the machine for any damage and repair the damage before restarting and operating the machine.

4. Exercise caution to avoid slipping or falling.

5. If the unit should start to vibrate abnormally, stop the engine, disconnect the spark plug wire and prevent it from touching the spark plug, and check immediately for the cause. Vibration is generally a warning of trouble.

6. Stop the engine, disconnect the spark plug wire and prevent it from touching the spark plug, whenever you leave the operating position, before unclogging the tines, or when making any repairs, adjustments or inspections.

7. Take all possible precautions when leaving the machine unattended. Stop the engine. Disconnect the spark plug wire and move it away from the spark plug. Be sure that both wheels are in the Wheel Drive position.

8. Before cleaning, repairing, or inspecting, stop the engine and make certain all moving parts have stopped. Disconnect the spark plug wire and prevent it from touching the spark plug to prevent accidental starting.

9. The flap on the tine hood must be down when operating the tiller.

10. Never use the tiller unless proper guards, plates, or other safety protective devices are in place.

11. Do not run the engine in an enclosed area. Engine exhaust contains carbon monoxide gas, a deadly poison that is odorless, colorless, and tasteless.

12. Keep children and pets away.

13. **Never operate the tiller under engine power if the wheels are in the Freewheel position.** In the Freewheel position, the wheels will not hold the tiller back and the revolving tines could propel the tiller rapidly, possibly causing loss of control. Always engage the wheels with the wheel drive pins in the Wheel Drive position before starting the engine or engaging the tines/wheels with the Forward Clutch Bail (all models) or the Reverse Clutch control (Models 634F/634B only).

14. **Be aware that the tiller may unexpectedly bounce upward or jump forward if the tines should strike extremely hard packed soil, frozen ground, or buried obstacles like large stones, roots, or stumps. If in doubt about the tilling conditions, always use the following**

**operating precautions to assist you in maintaining control of the tiller:**

a. **Walk behind and to one side of the tiller, using one hand on the handlebars. Relax your arm, but use a secure hand grip.**

b. **Use shallower depth regulator settings, working gradually deeper with each pass.**

c. **Use slower engine speeds.**

d. **Clear the tilling area of all large stones, roots and other debris.**

e. **Avoid using downward pressure on the handlebars. If need be, use slight upward pressure to keep the tines from digging too deeply.**

f. **Before contacting hard packed soil at the end of a row, reduce engine speed and lift the handlebars to raise the tines out of the soil.**

g. **In an emergency, stop the tines and wheels by releasing whichever clutch control is engaged. Do not attempt to restrain the tiller.**

15. Do not overload the tiller's capacity by attempting to till too deeply at too fast a rate.

16. Never operate the tiller at high transport speeds on hard or slippery surfaces. Look behind and use care when backing up.

17. Do not operate the tiller on a slope that is too steep for safety. When on slopes, slow down and make sure you have good footing. Never permit the tiller to freewheel down slopes.

18. Never allow bystanders near the unit.

19. Only use attachments and accessories that are approved by the manufacturer of the tiller.

20. Use tiller attachments and accessories when recommended.

21. Never operate the tiller without good visibility or light.

22. Never operate the tiller if you are tired; or under the influence of alcohol, drugs or medication.

23. Operators shall not tamper with the engine-governor settings on the machine; the governor controls the maximum safe operating speed to protect the engine and all moving parts from damage caused by overspeed. Authorized service shall be sought if a problem exists.

24. Do not touch engine parts which may be hot from operation. Let parts cool down sufficiently.

25. Please remember: You can always stop the tines and wheels by releasing the Forward Clutch Bail or on Models 634F and 634B the Reverse Clutch control, (whichever control is engaged), or by moving the ignition switch and/or throttle control lever on the engine to "OFF" or "STOP".

26. To load or unload the tiller, see the instructions in Section 4 of this Manual.

27. Use extreme caution when reversing or pulling the machine towards you.

28. Start the engine carefully according to instructions and with feet well away from the tines.

29. Never pick up or carry a machine while the engine is running.

## Maintenance and Storage

1. Keep the tiller, attachments and accessories in safe working condition.

2. Check all nuts, bolts, and screws at frequent intervals for proper tightness to be sure the equipment is in safe working condition.

3. Never store the tiller with fuel in the fuel tank inside a building where ignition sources are present such as hot water and space heaters, furnaces, clothes dryers, stoves, electric motors, etc.). Allow the engine to cool before storing the unit in any enclosure.

4. To reduce the chances of a fire hazard, keep the engine free of grass, leaves, or excessive grease.

5. Store gasoline in a cool, well-ventilated area, safely away from any spark- or flame-producing equipment. Store gasoline in an approved container, safely away from the reach of children.

6. Refer to the Maintenance sections of this Manual and the separate Engine Owner's Manual for instructions if the unit is to be stored for an extended period.

7. Never perform maintenance while the engine is running or the spark plug wire is connected, except when specifically instructed to do so.

8. If the fuel tank has to be drained, do this outdoors.

## Decals

For your safety and the safety of others, various safety and operational decals are located on your unit (see Figure 1-2).

Keep the decals clean and legible at all times. Contact your local service dealer or the factory for replacements if any decals are damaged or missing.

Refer to the Parts List pages in this Manual for decal locations, descriptions and part numbers.

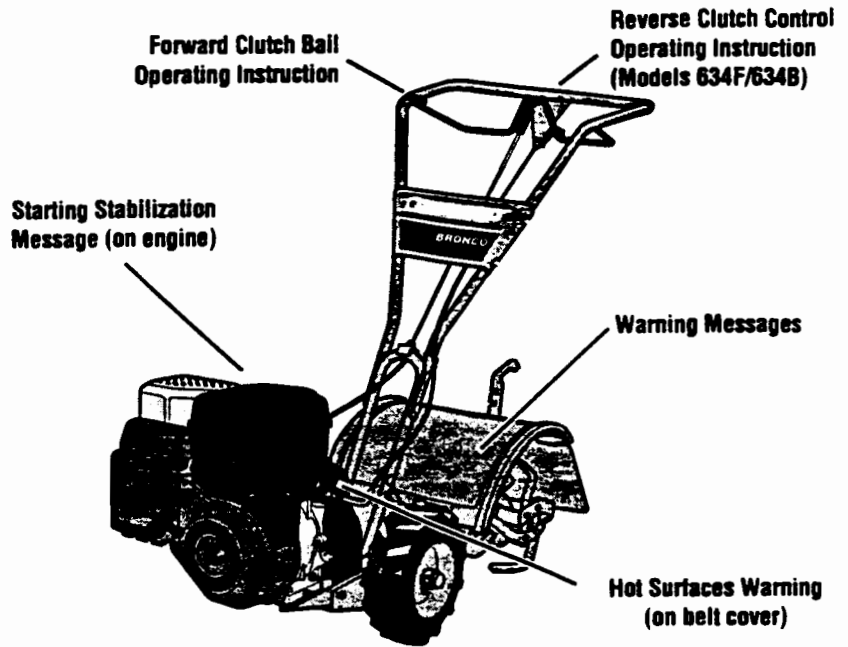

Figure 1-2: Location of safety and operating decals (5.5HP Model shown).

## Operating Symbols

Various symbols (shown here, with word descriptions) may be used on the tiller and engine. Your unit may not have all of the symbols.



FAST



SLOW



STOP



TILLER DIRECTION



CHOKE ON



CHOKE OFF

R  
REVERSE



ROTATING TINES



BAIL ENGAGED



BAIL DISENGAGED

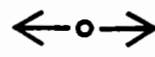

LEVER DIRECTION



## WARNING

### TO AVOID SERIOUS INJURY:

- READ THE OWNER'S MANUAL.
- KNOW LOCATIONS AND FUNCTIONS OF ALL CONTROLS.
- KEEP ALL SAFETY DEVICES AND SHIELDS IN PLACE AND WORKING.
- NEVER ALLOW CHILDREN OR UNINSTRUCTED ADULTS TO OPERATE TILLER.
- SHUT OFF ENGINE AND DISCONNECT SPARK PLUG WIRE BEFORE MANUALLY UNCLOGGING TINES OR MAKING REPAIRS.
- KEEP BYSTANDERS AWAY FROM MACHINE.
- KEEP AWAY FROM ROTATING PARTS.
- USE EXTREME CAUTION WHEN REVERSING OR PULLING THE MACHINE TOWARDS YOU.

**WARNING**

To prevent personal injury or property damage, do not start the engine until all assembly steps are complete and you have read and understand the safety and operating instructions in this manual.

**INTRODUCTION**

Carefully follow these assembly steps to correctly prepare your tiller for use. It is recommended that you read this Section in its entirety before beginning assembly.

NOTE: Various tiller models are presented in this Manual. Use only the information appropriate for your tiller model.

**INSPECT UNIT**

Inspect the unit and carton for damage immediately after delivery. Contact the carrier (trucking company) if you find or suspect damage. Inform them of the damage and request instructions for filing a claim. To protect your rights, put your claim in writing and mail a copy to the carrier within 15 days after the unit has been delivered. Contact the factory if you need assistance in this matter.

**TOOLS/MATERIALS NEEDED FOR ASSEMBLY**

- (1) 3/8" open-end wrench\*
- (2) 7/16" open-end wrench\*
- (2) 1/2" open-end wrench\*
- (2) 9/16" open-end wrench\*
- (1) Large adjustable wrench (Models 634F/634B only)
- (1) Scissors (to trim plastic ties)
- (1) Ruler (for belt tension check)
- (1) Block of wood (to support tiller when removing wheels)
- (1) Tire pressure gauge (for models with pneumatic tires)
- (1) Clean oil funnel
- (1) Motor oil. Refer to the Engine Owner's Manual for oil specifications and quantity required.

\* Adjustable wrenches may be used.

**ASSEMBLY STEPS****STEP 1: UNPACKING INSTRUCTIONS**

NOTE: While unpacking, do not severely bend any control cables.

1. The tiller weighs approximately 133 lbs. Do not attempt to remove it from the shipping platform until instructed to do so in these *Assembly* steps.
2. Remove any packaging material from the carton. Remove any staples from the bottom of the carton and remove the carton from the shipping platform.
3. Remove all unassembled parts and the separate hardware bag from the carton. Check that you have the items listed in the *Loose Parts List* (contact your local dealer or the factory items are missing or damaged). NOTE: Use the screw length template (Fig. 2-1) to identify screws.

**Loose Parts List**

Qty.	Description
1	Handlebar Support (see A, Fig. 2-2)
1	Handlebar Assembly (see K, Fig. 2-2)
<i>Hardware bag contents:</i>	
1	Slotted hd. screw, #10-24 x 2"
1	Hex hd. screw, 1/4-20 x 1-1/4"
6	Hex hd. screw, 5/16-18 x 1-1/2"
2	Hex hd. screw, 3/8-16 x 3/4"
2	Flat washer, 3/8"
6	Split lockwasher, 5/16"
1	Hex locknut, 1/4"-20
6	Hex nut, 5/16"-18
1	Hex nut, #10-24
2	Hex locknut, 3/8"-16
1	Spring, cable (see W, Fig. 2-5)
1	Bracket, forward clutch cable (see P, Fig. 2-4)
2	Lock Washer, 3/8"
2	*Self-tapping screw, 1/4-20 x 1/2"
1	*Bracket, reverse clutch cable

\*Model 634F & 634B only

**IMPORTANT:** Motor oil must be added to the engine crankcase before the engine is started. Follow the instructions in this *Assembly* Section and in the separate *Engine Owner's Manual*.

NOTE: LEFT and RIGHT sides of the tiller are as viewed from the operator's position behind the handlebars.

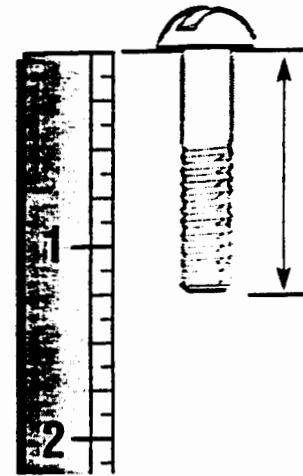

Figure 2-1: To identify length of screws, place screw on template as shown and measure distance between bottom of screw head and tip of screw.

**STEP 2: ATTACH HANDLEBAR**

1. Loosely attach the legs of the handlebar support (A, Fig. 2-2) to the inner sides of the tiller frame using two 3/8"-16 x 3/4" hex hd. screws (B), 3/8" flat washers (C), 3/8" lock washers (GG) and 3/8"-16 hex locknuts (D).
2. There are three height adjustment holes in the two handlebar support brackets (E and F, Fig. 2-2). Use a setting that will position the handlebars at approximately waist level when the tines are 3"-4" into the soil. Loosely attach the support brackets to the handlebar support (A) using two 5/16"-18 x 1-1/2" screws (G), 5/16" split lockwashers (H) and 5/16"-18 hex nuts (I). NOTE: If a support bracket will not move, loosen attaching screw (J) and nut.
3. Attach the handlebar assembly (K) to the handlebar support (A) using four 5/16"-18 x 1-1/2" screws (G), 5/16" split lockwashers (H) and 5/16"-18 hex nuts (I). Tighten the four screws securely.
4. Tighten all handlebar mounting hardware securely.

**STEP 3: MOVE TILLER OFF SHIPPING PLATFORM**

To roll the tiller off the shipping platform, put the wheels in FREEWHEEL, as follows:

1. Place a sturdy block under the transmission to raise one wheel about 1" off the ground.

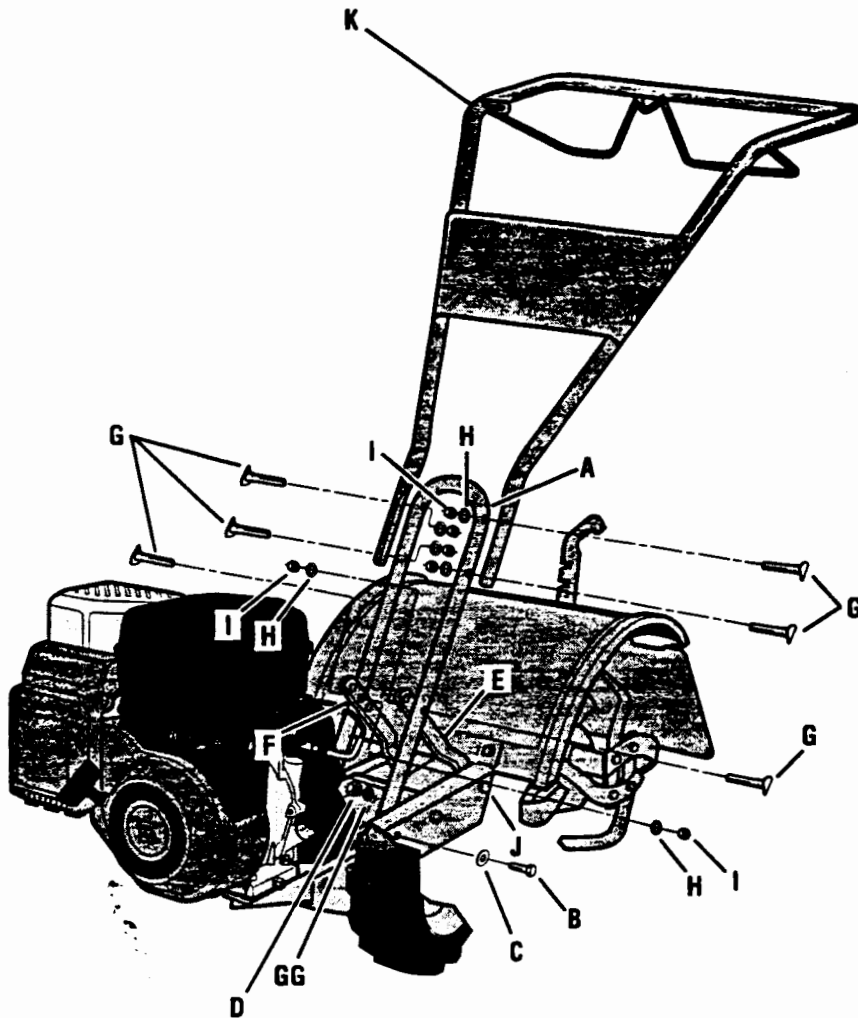

Fig. 2-2: Attach handlebar (5.5HP Model shown).

2. Remove the hairpin cotter (L, Fig. 2-3) and wheel drive pin (M) from the wheel hub (O) and wheel shaft (N).

3. Slide the wheel fully inward on the wheel shaft (N, Fig. 2-3). Reinstall the wheel drive pin (M) through the wheel shaft only (not through the wheel hub). Secure the wheel drive pin with the hairpin cotter (L), pushing the hairpin cotter in as far as it will go. The wheel should now spin freely (freewheel) on the wheel shaft. Repeat with the other wheel.

4. Use the handlebar to roll the tiller to a flat area.

**IMPORTANT:** Before starting the engine, the wheels must be placed in the WHEEL DRIVE position (pins through wheel hubs and wheel shaft). This procedure is described in *Wheel Drive Pins* in Section 3.

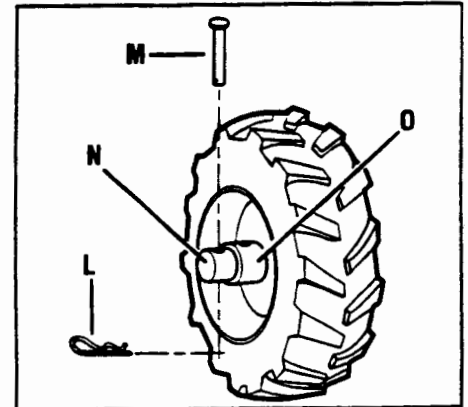

Fig. 2-3: Wheel in FREEWHEEL position (wheel drive pin through wheel shaft only).

#### STEP 4: INSTALL FORWARD CLUTCH CABLE

1. Attach the forward clutch cable bracket (P, Fig. 2-4) to the handlebar support (A) with a 1/4"-20 x 1-1/4" hex hd. screw (R) and 1/4"-20 hex locknut (S). Tighten securely.

2. Carefully unwrap the forward clutch cable (cable without an attached knob) from its shipping position and slide the thin cable wire (T, Fig. 2-4) into the slot in the cable bracket. Push the cable connector (U, Fig. 2-4) up through the hole in the bracket until the groove in the connector snaps into place.

3. Insert the #10-24 x 2" slotted hd. screw (V, Fig. 2-5) down through the hooked end of the cable spring (W) until the screw threads extend through the spring.

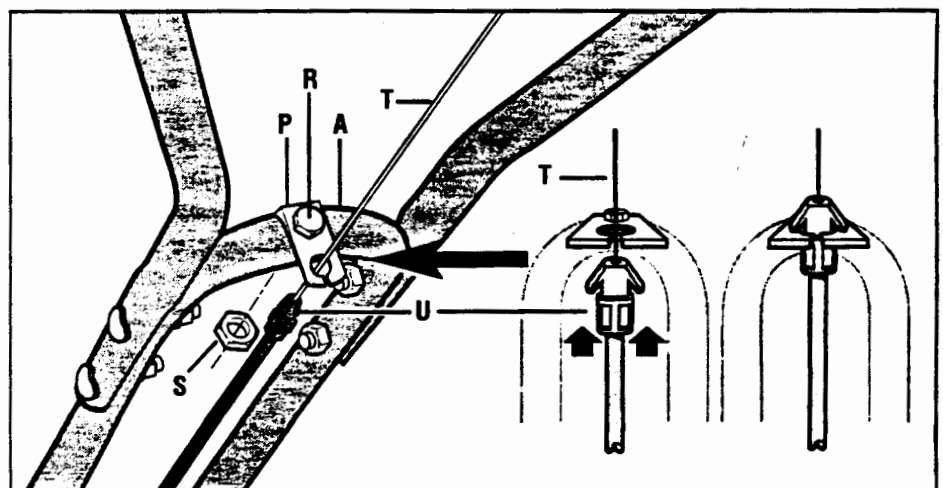

Fig. 2-4: Installing forward clutch cable bracket and cable.

4. Thread the #10-24 hex nut (Z, Fig. 2-5) halfway onto the screw (V).

5. Thread the screw (V) into the cable adjuster (X).

6. Hook the cable spring (W, Fig. 2-6) into the V-shaped bend in the Forward Clutch Bail (Y).

7. Check for correct tension on the forward drive belt by taking two measurements of the cable spring, as follows:

a. With the Forward Clutch Bail (Y, Fig. 2-6) in an open (released) position, measure the length of the cable spring (W) from the outermost coil to the outermost coil.

b. Squeeze the Forward Clutch Bail against the handlebar (see Fig. 2-7) and re-measure the spring length. The belt tension is correct if this second measurement is between 1/16" to 3/16" longer than the first measurement. If so, turn the hex nut (Z, Fig. 2-7) tightly against the cable adjuster (X) while preventing the cable adjuster from turning.

c. If the spring length is incorrect, you must adjust the cable tension as described in *Checking and Adjusting Forward Drive Belt Tension* in Section 5. Incorrect cable tension can result in belt slippage (cable tension too loose), or unintentional tine movement when the clutch bail is in Neutral (cable tension too tight).

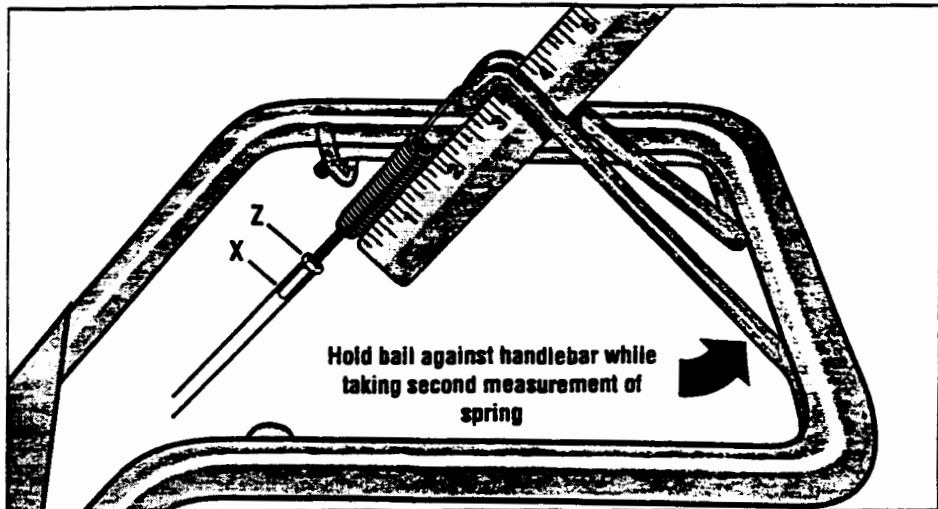

Fig. 2-7: To check forward belt tension, take two measurements of the length of the coils in the spring – first with the bail open, then with the bail held against the handlebar.

**STEP 5: INSTALL REVERSE CLUTCH CABLE (MODELS 634F AND 634B ONLY)**

1. Unwrap the reverse clutch cable (CC, Fig. 2-8 and Fig. 2-9) from its shipping position and route it up to the handlebar. Be sure that the cable is routed beneath the Forward Clutch Bail.

2. Using the two self-tapping screws (AA, Fig. 2-8) secure the reverse cable mounting bracket (BB) to the handlebars, as shown.

3. Insert the cable (CC, Fig. 2-8) through the slot in the cable bracket and position the flat side of the threaded assembly next to the flat side of the hole. Slide the hex nut (DD) up the cable and tighten it securely.

4. Fasten the reverse clutch cable to the left side handlebar with a cable tie (EE, Fig. 2-9).

5. Test the function of the reverse clutch by pulling out and releasing the cable knob. The knob should return to its neutral position (resting against bracket). If it doesn't, contact your local dealer or the factory for technical assistance.

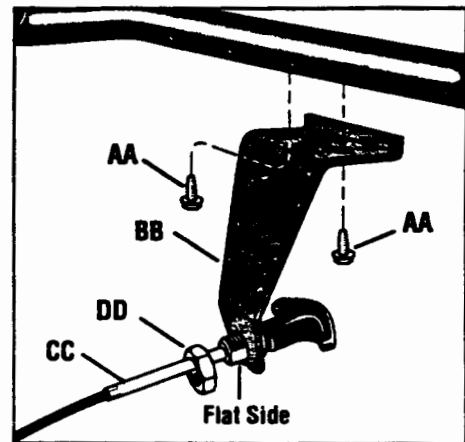

Fig. 2-8: Install reverse cable bracket and reverse clutch cable.

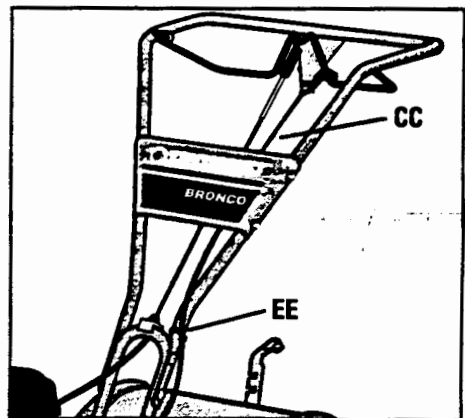

Fig. 2-9: Route reverse clutch cable (CC) as shown. Attach with cable tie (EE).

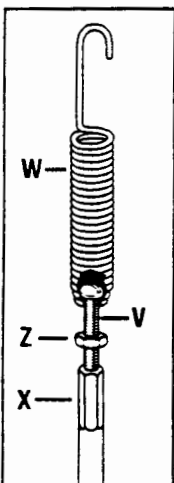

Fig. 2-5: Cable spring and adjuster.

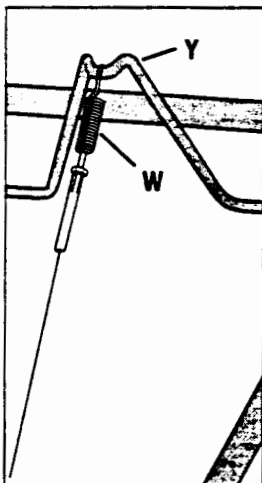

Fig. 2-6: Attach forward clutch cable spring to forward clutch bail.



### STEP 6: CHECK LEVEL OF TRANSMISSION GEAR OIL

The transmission was filled with gear oil at the factory. However, you should check the gear oil level at this time to make certain it is correct.

**IMPORTANT:** Do not operate the tiller if the gear oil level is low. Doing so will result in severe damage to the transmission components.

1. With the tiller on level ground, pull the Depth Regulator Lever (FF, Fig. 2-10) back and then all the way up until the lowest notch in the lever is engaged.
2. Remove the oil fill plug (GG, Fig. 2-11) from the transmission housing cover and locate the main drive shaft situated inside the housing.
3. The gear oil level is correct if the gear oil is approximately halfway up the side of the main drive shaft.
4. If the oil level is low, add gear oil by referring to *A. To Check the Transmission Gear Oil Level* in Section 5.

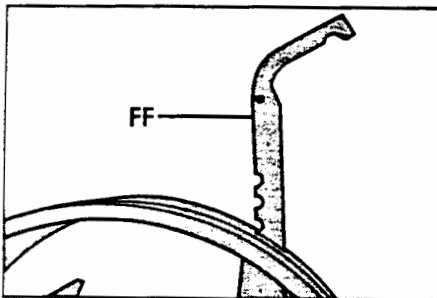

Fig. 2-10: Adjust Depth Regulator Lever.



Fig. 2-11: Remove gear oil fill plug.

### STEP 7: ADD MOTOR OIL TO ENGINE

The tiller is shipped *without* oil in the engine.

**IMPORTANT:** Do not start the engine without first adding motor oil. Severe engine damage will result if the engine is run without oil.

1. Refer to the separate Engine Owner's Manual for engine oil specifications and capacities.
2. With the tiller on level ground, move the Depth Regulator Lever (FF, Fig. 2-10) up or down until the engine is level.
3. Add motor oil as described in the Engine Owner's Manual.
4. Move the Depth Regulator Lever all the way down until the highest notch is engaged. This places the tines in the "travel" position, which allows the tiller to be moved without the tines touching the ground.

### STEP 8: CHECK HARDWARE FOR TIGHTNESS

Check all nuts and screws for tightness.

### STEP 9: CHECK AIR PRESSURE IN TIRES (units with pneumatic tires)

On tires equipped with air valves, check the air pressure with a tire gauge. Deflate or inflate the tires equally to 15 to 20 PSI (pounds per square inch). Be sure that both tires are inflated equally or the unit will pull to one side.

**IMPORTANT:** This completes the assembly steps. Before operating your tiller, make sure you read the following sections in this Manual, as well as the separate Engine Owner's Manual:

- Section 1: *Safety*
- Section 3: *Features and Controls*
- Section 4: *Operation*

# Features and Controls

## ⚠ WARNING

Before operating your machine, carefully read and understand all safety, controls and operating instructions in this Manual, the separate Engine Owner's Manual, and on the decals on the machine.

Failure to follow these instructions can result in serious personal injury.

## INTRODUCTION

This Section describes the location and function of the controls on your tiller. Refer to the following Section, *Operation* for detailed operating instructions.

Practice using these controls, with the engine shut off, until you understand the operation of the controls and feel confident with each of them.

## ENGINE CONTROLS

Refer to the engine manufacturer's Engine Owner's Manual (included in the tiller literature package) to identify the controls on your engine.

**IMPORTANT:** The control for stopping the engine is located on the engine.

## WHEEL DRIVE PINS

Each wheel is equipped with a wheel drive pin (A, Figures 3-2 and 3-3) that secures the wheel to the wheel shaft (B). The wheels can be positioned in either a WHEEL DRIVE or a FREEWHEEL mode.

## ⚠ WARNING

Never allow either of the wheels to be in the FREEWHEEL position when the engine is running. Always put both wheels in the WHEEL DRIVE position before starting the engine.

Failure to comply could cause loss of tiller control, property damage, or personal injury.

Before starting the engine, put both wheels in the WHEEL DRIVE position by inserting the wheel drive pins through the wheel hubs and the wheel shaft. Doing so "locks" the wheels to the wheel shaft, causing the wheels to turn when either the

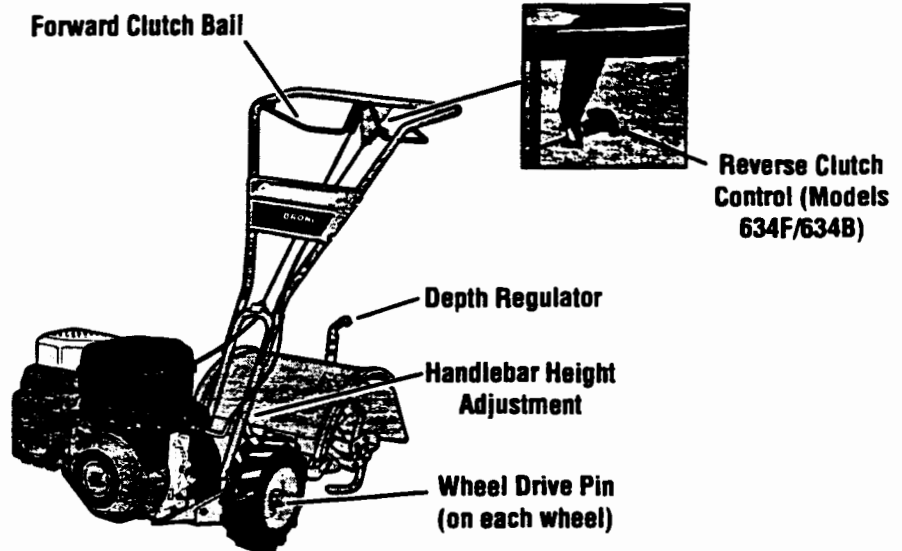

Figure 3-1: Tiller features and controls (5.5HP Model shown). See separate Engine Owner's Manual to identify engine controls.

Forward Clutch Bail (all models) or the Reverse Clutch Control (Models 634F and 634B) is engaged.

Use the FREEWHEEL mode only when the engine is not running. In FREEWHEEL, the wheel drive pins are placed only through the holes in the wheel shaft (not the wheel hubs), thus allowing the wheels to turn freely when you manually move the tiller.

To place the wheels in WHEEL DRIVE or FREEWHEEL:

1. Stop engine, disconnect spark plug wire from spark plug and allow engine to cool.

## ⚠ WARNING

Do not place tiller on its side when changing wheel drive positions. Doing so could result in gasoline leaking from the fuel tank.

Failure to follow this instruction could result in personal injury or property damage.

2. Raise one wheel about one inch off the ground and place a sturdy support under the transmission.

3. Remove hairpin cotter (C, Figures 3-2 and 3-3) from wheel drive pin (A).

4. FOR WHEEL DRIVE MODE (Figure 3-2): Slide wheel outward and align holes in wheel hub (D, Figure 3-2) and wheel shaft (B). Insert wheel drive pin (A) through

wheel hub (D) and wheel shaft (B). Secure wheel drive pin with hairpin cotter (C) by pushing hairpin cotter in as far as it will go. Repeat with the other wheel and then remove the support from beneath the transmission.

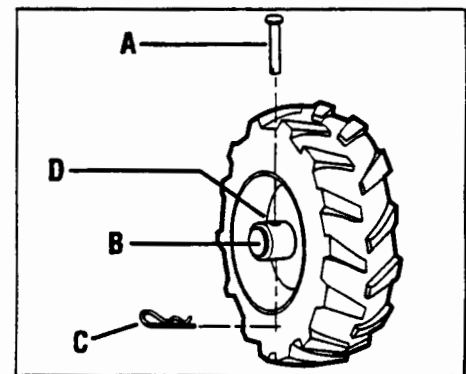

Figure 3-2: WHEEL DRIVE position.

5. FOR FREEWHEEL MODE (Figure 3-3): Slide the wheel inward and insert the wheel drive pin (A, Figure 3-3) only through the hole in the wheel shaft (B). Secure wheel drive pin with hairpin cotter (C) by pushing hairpin cotter in as far as it will go. Repeat for the other wheel and then remove the support from beneath the transmission.

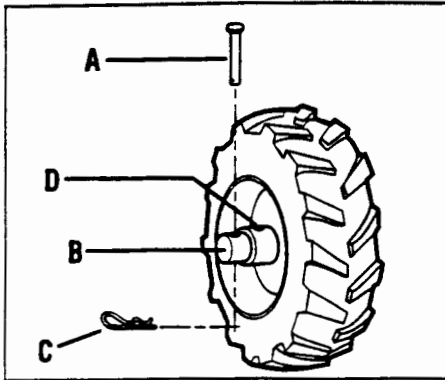

Figure 3-3: FREEWHEEL position.

**⚠ WARNING**

Before starting engine, be sure that both wheels are in WHEEL DRIVE position. See *Wheel Drive Pins* for instructions.

Engaging the Forward Clutch Bail or Reverse Clutch Control (if equipped) when the wheels are not in WHEEL DRIVE could allow the tines to rapidly propel the tiller forward or backward.

Failure to comply could cause loss of tiller control, property damage, or personal injury.

**FORWARD CLUTCH BAIL**

The Forward Clutch Bail (E, Figure 3-4) controls the engagement of forward drive to the wheels and tines.

To operate the Forward Clutch Bail:

1. Put wheels in WHEEL DRIVE position (see "WARNING" statement above).
2. Lift and hold the clutch bail (E, Figure 3-4) against the handlebar to start the wheels and tines rotating in a forward direction.
3. Release the clutch bail to disengage (stop) the wheels and tines (the engine will continue to run).

**REVERSE CLUTCH CONTROL (Models 634F/634B only)**

The Reverse Clutch Control (F, Figure 3-4) controls the engagement of reverse drive to the wheels and tines. The reversing feature is used for maneuvering the tiller only – never engage the tines in the ground while operating in reverse.

**⚠ WARNING**

Use extreme caution when reversing or pulling the machine towards you. Look behind to avoid obstacles.

Never attempt to till in reverse.

Failure to follow this warning could result in personal injury or property damage.

To operate the Reverse Clutch Control:

1. Put wheels in WHEEL DRIVE position (see "WARNING" statement at the left).
2. Stop all tiller motion by releasing the Forward Clutch Bail.
3. Lift the handlebar until the tines clear the ground, look behind you to avoid any obstacles, and then pull the control knob (F, Figure 3-4) out. The wheels and tines will rotate in a reverse direction.
4. Release the control knob to disengage (stop) the wheels and tines (the engine will continue to run).

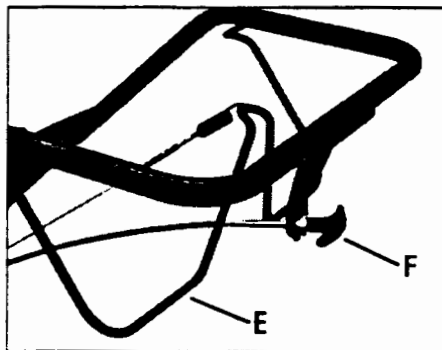

Figure 3-4: All models have a Forward Clutch Bail (E). Only Models 634F/634B have a Reverse Clutch Control (F).

**DEPTH REGULATOR LEVER**

This lever (G, Figure 3-5) controls the tilling depth of the tines. Pull the lever back and slide it up or down to engage the notched height settings.

The "travel position" (highest notch) raises the tines approximately 1-1/2' off the ground, allowing the tiller to be moved without the tines contacting the ground. This setting should also be used when starting the engine.

Moving the lever upward will increase the tilling depth. The lowest notch allows a tilling depth of approximately 6", depending on soil conditions. For best

results, always begin tilling at a very shallow depth setting and gradually increase the tilling depth.

**⚠ WARNING**

Do not attempt to till too deeply too quickly. Gradually work down to deeper tilling depths.

Place the Depth Regulator Lever in the "travel" position before starting the engine. This position prevents the tines from touching the ground until you are ready to begin tilling.

Failure to follow this warning could result in personal injury or property damage.

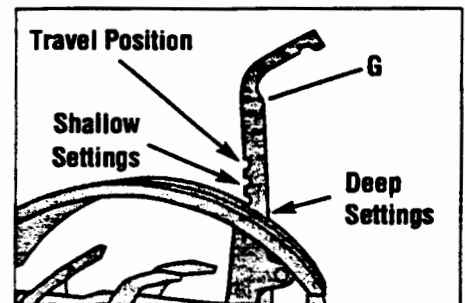

Figure 3-5: Depth Regulator Lever (G).

**HANDLEBAR HEIGHT ADJUSTMENT**

The handlebar height is adjustable to three different settings (Figure 3-6). In general, adjust the handlebars so they are at waist level when the tines are 3"-4" in the soil.

To adjust the handlebars:

1. Stop engine, disconnect spark plug wire from spark plug and allow engine to cool.
2. Remove hardware, reposition handlebars, and reinstall hardware securely.

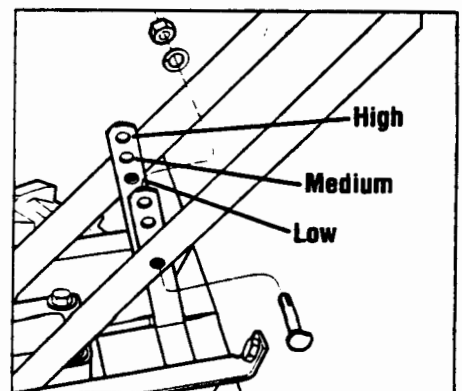

Figure 3-6: Handlebar height adjustment.

**⚠ WARNING**

Before operating your machine, carefully read and understand all safety (Section 1), controls (Section 3) and operating instructions (Section 4) in this Manual, in the separate Engine Owner's Manual, and on the decals on the machine.

Failure to follow these instructions can result in serious personal injury.

**INTRODUCTION**

Read this *Operation* Section and the separate Engine Owner's Manual before you start the engine. Then, take the time to familiarize yourself with the basic operation of the tiller before using it in the garden. Find an open, level area and practice using the tiller controls without the tines engaging the soil (put tines in "travel" setting). Only after you've become completely familiar with the tiller should you begin using it in the garden.

**BREAK-IN OPERATION**

Perform the following maintenance after the first two (2) hours of new operation (see *Maintenance* Section in this manual and in the Engine Owner's Manual).

1. Change engine oil.
2. Check for loose or missing hardware on unit. Tighten or replace as needed.
3. Check tension on forward drive belt.
4. Check transmission gear oil level.

**STARTING AND STOPPING THE ENGINE****Pre-Start Checklist**

With the spark plug wire disconnected from the spark plug, perform the following checks and services before each use:

1. Read the *Safety* and *Controls* Sections in this manual. Read the separate Engine Owner's Manual provided with the unit.
2. Put the wheels in the WHEEL DRIVE position (wheel pins must be through holes in wheel hubs and wheel shaft).
3. Check unit for loose or missing hardware. Service as required.
4. Check engine oil level. See Engine Owner's Manual.

Reverse Clutch Control  
(Models 634F/634B)



Forward Clutch Ball

Depth Regulator

Recoil Starter

Wheel Drive Pin  
(on each wheel)



Fig. 4-1

5. Check that all safety guards and covers are in place.
6. Check air cleaner and engine cooling system. See Engine Owner's Manual.

**⚠ DANGER**

**GASOLINE IS HIGHLY FLAMMABLE AND ITS VAPORS ARE EXPLOSIVE.**

Follow gasoline safety rules in this Manual (see Section 1) and in the separate Engine Owner's Manual.

Failure to follow gasoline safety instructions can result in serious personal injury and property damage.

7. Fill the fuel tank with gasoline according to the directions in the separate Engine Owner's Manual. Follow all instructions and safety rules carefully.
8. Attach spark plug wire to spark plug.

**Starting the Engine**

The following steps describe how to start and stop the engine. **Do not attempt to engage the tines or wheels until you have read all of the operating instructions in this Section. Also, review the safety rules in Section 1: Safety, and the tiller and engine controls information in Section 3: Features and Controls.**

1. Complete the *Pre-Start Checklist* on this page.
2. Put the wheels in the WHEEL DRIVE position (see *Wheel Drive Pins* in Section 3 of this manual).

**⚠ CAUTION**

To help prevent serious personal injury or damage to equipment:

- Before starting engine, put both wheels in the WHEEL DRIVE position. Never have wheels in FREEWHEEL position when engine is running. When the wheels are in FREEWHEEL, they do not hold back the tiller and the tines could propel the tiller rapidly forward or backward.
- Before starting engine, put Forward Clutch Ball (all models) and Reverse Clutch Control (Models 634F/634B only) in neutral (disengaged) positions by releasing levers.
- Never run engine indoors or in enclosed, poorly ventilated areas. Engine exhaust contains carbon monoxide, an odorless and deadly gas.
- Avoid engine muffler and nearby areas. Temperatures in these areas may exceed 150°F.

3. Move the Depth Regulator Lever all the way down to the "travel" position, so that the tines clear the ground.
4. Release all controls on the tiller.
5. On engine's with a fuel shut-off valve, turn valve to open position, as instructed in the separate Engine Owner's Manual.
6. Put ignition switch and/or throttle control lever located on engine in the "ON", "RUN", "FAST" or "START" position, as instructed in the Engine Owner's Manual.
7. Choke or prime engine, as instructed in Engine Owner's Manual.
8. Put one hand on fuel tank to stabilize unit when pulling starter rope handle. Then use recoil starter to start engine, as instructed in the Engine Owner's Manual. When engine starts, gradually move choke lever (if so equipped) to "NO CHOKE", "CHOKE OFF" or "RUN" position.
9. Use the "FAST" throttle speed setting when tilling.

**⚠ WARNING**

Keep away from rotating tines. Rotating tines will cause injury.

**Stopping the Engine and Tiller**

1. To stop the wheels and tines, release the Forward Clutch Bail (all models) or the Reverse Clutch Control (Models 634F and 634B) – whichever control is in use.
2. To stop the engine, put the ignition switch and/or the throttle control lever in the “OFF” or “STOP” position.

**OPERATING THE TILLER**

The following operating instructions provide guidelines to using your tiller effectively and safely. Be sure to read *Tilling Tips & Techniques* in this Section before actually putting the tines into the soil.

NOTE: This is a traditional “Standard-Rotating-Tine” (SRT) tiller with forward rotating tines. It operates completely differently from “Counter-Rotating-Tine” (CRT) tillers or from front-tine tillers.

1. Follow the *Pre-Start Checklist* at the beginning of this Section. Be sure that the wheels are in the WHEEL DRIVE position.
2. Move the Depth Regulator Lever all the way down, so that the tines clear the ground. Use this position when practicing with the tiller and when traveling between tilling sites. Before actually tilling, move the lever to the desired depth setting (see *Tilling Tips & Techniques*).
3. Start engine and allow it to warm up. Then put throttle in “FAST” setting.



Fig. 4-2: Use one hand to guide tiller when moving forward.

4. For forward motion of the wheels and tines:

- (a) Pull Forward Clutch Bail (Fig. 4-1) up against handlebar. Release bail to stop forward motion of wheels and tines.
- (b) When tilling, relax and let the wheels pull the unit while the tines dig. Walk behind and a little to one side of the unit. Use one hand, yet keep a light—but secure—grip on the handlebar (while keeping your arm loose). See Fig. 4-2. Let the unit move at its own pace and do not push down on the handlebars to try and force the tines to dig deeper — this takes weight off the wheels, reduces traction, and causes the tines to try and propel the tiller.

**⚠ WARNING**

Do not push down on the handlebars to try to make the tiller till more deeply. This prevents the wheels from holding the tiller back and can allow the tines to rapidly propel the tiller forward, which could result in loss of control, property damage, or personal injury.

5. For reverse motion of the wheels and tines (Models 634F/634B only):

- (a) Look behind and exercise caution when operating in reverse. Do not till while in reverse.
- (b) Stop all forward motion. Lift handlebar with one hand until tines are off the ground and then pull Reverse Clutch Control knob out (see Fig. 4-3). To stop reversing, let go of Reverse Clutch Control knob.



Fig. 4-3: Raise tines off ground and look behind when moving in reverse.

6. To move the Model 630B in reverse for short distances:

- (a) Release Forward Clutch Bail. Then lift handlebar until tines are off the ground.

- (b) Swing the handlebar to the left so the right wheel takes a “step” backward. Next swing the handlebar to the right so the left wheel “steps” backward. Repeat as needed.
  - (c) If longer distances need to be covered in reverse, shut off the engine, then place the two wheels in FREEWHEEL.
7. To Turn the Tiller Around:
    - (a) Practice turning the tiller in a level, open area. Be very careful to keep your feet and legs away from the tines.
    - (b) To begin a turn, lift the handlebars until the tines are out of the ground and the engine and tines are balanced over the wheels (Fig. 4-4).
    - (c) With tiller balanced, push sideways on handlebar to steer in direction of turn (Fig. 4-5). After turning, slowly lower tines into soil to resume tilling.



Fig. 4-4: To begin turn, lift handlebars until tines are out of ground and unit is balanced.



Fig. 4-5: With tines out of ground, push handlebars sideways to turn tiller.

**Stopping the Tiller and Engine**

1. To stop the wheels and tines, release the Forward Clutch Bail (all models) or the Reverse Clutch Control (Models 634F and 634B) – whichever control is in use.
2. To stop the engine, put the ignition switch and/or the throttle control lever in the “OFF” or “STOP” position.

## TILLING TIPS & TECHNIQUES

### Tilling Depths

#### ⚠ WARNING

Before tilling, contact your telephone or utilities company and inquire if underground equipment or lines are used on your property. Do not till near buried electric cables, telephone lines, pipes or hoses.

- Avoid pushing down on the handlebars in an attempt to force the tiller to dig deeper. Doing so takes the weight off the powered wheels, causing them to lose traction. Without the wheels helping to hold the tiller back, the tines will attempt to propel the tiller – often causing the tiller to skip rapidly across the ground. (Sometimes, slight downward pressure on the handlebars will help get through a particularly tough section of sod or unbroken ground, but in most cases this won't be necessary.)
- Avoid trying to dig too deeply too quickly, especially when busting sod or when tilling soil that hasn't been tilled for some time. Use shallow depth regulator settings (only an inch or two deep) for the first passes through the soil. With each succeeding pass, dig another inch or two deeper. (Watering the area a few days prior to tilling will make tilling easier, as will letting the newly worked soil set for a day or two before making a final, deep tilling pass.)

- When cultivating (breaking up surface soil around plants to destroy weeds, see Fig. 4-9), adjust the tines to dig only 1' to 2' deep. Using shallow tilling depths helps prevent injury to plants whose roots often grow close to the surface. If needed, lift up on the handlebars slightly to prevent the tines from digging too deeply. (Cultivating on a regular basis not only eliminates weeds, it also loosens and aerates the soil for better moisture absorption and faster plant growth.)

### Choosing Correct Wheel and Tine Speeds

With experience, you will find the "just right" tilling depth and tilling speed combination that is best for your garden.

Set the engine throttle lever at a speed to give the engine adequate power and yet allow it to operate at the slowest possible speed...at least until you have achieved the maximum tilling depth you desire. Faster engine speeds may be desirable when making final passes through the seedbed or when cultivating. Selection of the correct engine speed, in relation to the tilling depth, will ensure a sufficient power level to do the job without causing the engine to labor.

### Let the Tiller Do the Work

While tilling, relax and let the wheels pull the tiller along while the tines do the digging. Walk on the side that is not yet finished (to avoid making footprints in the freshly tilled soil) and lightly, but securely grip the handlebar with just one hand.

### Avoid Making Footprints

Whenever possible, walk on the untilled side of the unit to avoid making footprints in your freshly tilled or cultivated soil. Footprints cause soil compaction that can hamper root penetration and contribute to soil erosion. They can also "plant" unwanted weed seeds back into the freshly tilled ground.

### Avoid Tilling Soggy, Wet Soil

Tilling wet soil often results in large, hard clumps of soil that can interfere with planting. If time permits, wait a day or two after heavy rains to allow the soil to dry before tilling. Test soil by squeezing it into a ball. If it compresses too easily, it is too wet to till.

### Preparing Seedbeds

- When preparing a seedbed, go over the same path twice in the first row, then overlap one-half the tiller width on the rest of the passes (see Fig. 4-6). When finished in one direction, make a second pass at a right angle, as shown in Fig. 4-7. Overlap each pass for best results (in very hard ground, it may take three or four passes to thoroughly pulverize the soil.)

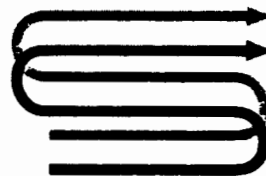

Fig. 4-6

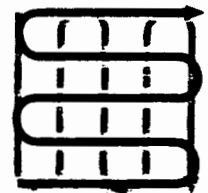

Fig. 4-7

- If the garden size will not permit lengthwise and then crosswise tilling, then overlap the first passes by one-half a tiller width, followed by successive passes at one-quarter width (see Fig. 4-8).



Fig. 4-8

### Cultivating

With planning, you can allow enough room between rows to cultivate (see Fig. 4-9). Leave room for the hood width, plus enough extra room for future plant growth.



Fig. 4-9

## TILLING TIPS & TECHNIQUES (cont.)

### Power Composting

Power composting simply means tilling under and burying in the soil all manner of organic matter such as crop residues, leaves, grass clippings and cover crops. This material will decompose during the non-growing season and add important natural nutrients to the soil.

The first place to begin is with crop residues such as leftover vines, stalks, stems and roots. Power compost these crop residues as soon as they finish bearing. The sooner this is done, the better, as tender green matter is easier to till under. Use the deepest depth regulator setting possible without causing the engine to labor or the tiller to jump ahead.

Standing cornstalks of reasonable height can be power composted. Pushing over (but not uprooting) cornstalks will often make it easier to chop up the stalks. Keep the tines clear of excessive tangling by "fishtailing" or frequently using reverse. Make several passes, then return a few days later to finish off any remaining stubble.

After tilling under crop residues, add more organic matter such as leaves, grass clippings and even kitchen scraps. When tilled into the soil, this organic matter will decompose and add even more important nutrients to the soil.

After power composting, you may want to plant a "green manure" cover crop to protect the soil during the off-season. You simply grow a crop of clover, alfalfa, buckwheat, peas, beans, rye grass, grain, or kale and then till it into the soil prior to the planting season.

### ⚠ WARNING

**When power composting, do not keep the Depth Regulator Lever at a deep setting if the tiller jumps or bucks.**

**If jumping or bucking occurs, move the Depth Regulator Lever down to a shallow setting and then slowly increase the tilling depth on later passes.**

**Failure to follow this warning could result in personal injury.**

### Tilling on Slopes

**Read the following recommendations before tilling on slopes:**

If you must garden on a moderate slope, please follow two very important guidelines:

1. Till only on moderate slopes, never on steep ground where footing is difficult (review safety rules in Section 1: *Safety* of this manual).
2. We recommend tilling up and down slopes rather than terracing. Tilling vertically on a slope allows maximum planting area and also leaves room for cultivating.

**IMPORTANT:** When tilling on slopes, be sure the correct oil level is maintained in the engine (check every one-half hour of operation). The incline of the slope will cause the oil to slant away from its normal level and this can starve engine parts of required lubrication. Keep the motor oil level at the full point at all times!

#### Tilling Up and Down Slopes (Vertical Tilling)

- To keep soil erosion to a minimum, be sure to add enough organic matter to the soil so that it has good moisture-holding texture and try to avoid leaving footprints or wheel marks.
- When tilling vertically, try to make the first pass uphill as the tiller digs more deeply going uphill than it does downhill. In soft soil or weeds, you may have to lift the handlebars slightly while going uphill. When going downhill, overlap the first pass by about one-half the width of the tiller.

#### Terrace Gardening

- When a slope is too steep or too short for vertical tilling, it may be necessary to till across the slope and create terraced rows. Terraces are rows that are cut into the side of a slope, creating a narrow, but flat area on which to plant.
- On a long slope, you can make several terraces, one below the other.
- Terraces should be only 2-to-3 feet wide. Digging too far into the side of the slope will expose poor subsoil that is unproductive for plants.

### ⚠ WARNING

**Do not operate tiller on a slope too steep for safe operation. Till slowly and be sure you have good footing. Never permit tiller to freewheel down slopes. Failure to follow this warning could result in personal injury.**

#### Tilling Across Slopes Without Using Terraces (Horizontal Tilling)

- If vertical or terracing gardening aren't practical for you, then you can till laterally across a slope. We don't recommend this method as it can create unsure footing and invites soil erosion.
- As in terrace gardening, start at the top of the slope and overlap the first pass by half the width of the tiller. For added stability of the tiller, always keep the uphill wheel in the soft, newly tilled soil.

## TILLING TIPS & TECHNIQUES (cont.)

### Terrace Gardening (continued)

- To create a terrace, start at the top of the slope and work down. Go back and forth across the first row as shown in Fig. 4-10.
- Each succeeding lower terrace is started by walking below the terrace you're preparing. For added stability of the tiller, always keep the uphill wheel in the soft, newly tilled soil. Do not till the last 12" or more of the downhill outside edge of each terrace. This untilled strip helps prevent the terraces from breaking apart and washing downhill. It also provides a walking path between rows.

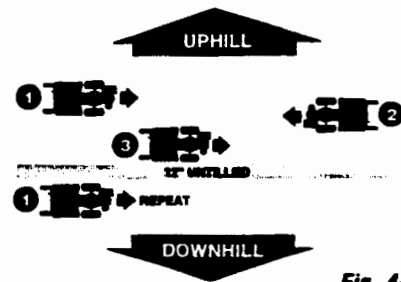

Fig. 4-10

### Clearing the Tines

The tines have a self-clearing action which eliminates most tangling of debris in the tines. However, occasionally dry grass, stringy stalks or tough vines may become tangled. Follow these procedures to help avoid tangling and to clean the tines, if necessary.

- To reduce tangling, set the depth regulator deep enough to get maximum "chopping" action as the tines chop the material against the ground. Also, try to till under crop residues or cover crops while they are green, moist and tender.
- While power composting, try swaying the handlebars from side to side (about 6" to 12"). This "fishtailing" action often clears the tines of debris.
- If tangling occurs, lift the tines out of the soil and run the tiller in reverse (if unit is equipped with powered reverse) for a few feet. This reversing action should unwind a good deal of debris.

- It may be necessary to remove the debris by hand (a pocket knife will help you to cut away the material). Be sure to stop the engine and disconnect the spark plug wire before clearing the tines by hand.

### ⚠ WARNING

Before clearing the tines by hand, stop the engine, allow all moving parts to stop and disconnect the spark plug wire. Remove the ignition key on electric start models.

Failure to follow this warning could result in personal injury.

## LOADING AND UNLOADING THE TILLER

### ⚠ WARNING

Loading and unloading the tiller into a vehicle is potentially hazardous and we don't recommend doing so unless absolutely necessary, as this could result in personal injury or property damage.

However, if you must load or unload the tiller, follow the guidelines given next.

- Before loading or unloading, stop the engine, wait for all parts to stop moving, disconnect the spark plug wire and let the engine and muffler cool.
- The tiller is too heavy and bulky to lift safely by one person. Two or more people should share the load.
- Use sturdy ramps and manually (engine shut off) roll the tiller into and out of the vehicle. Two or more people are needed to do this.
- The ramps must be strong enough to support the combined weight of the tiller and any handlers. The ramps should provide good traction to prevent slipping; they should have side rails to guide the tiller along the ramps; and they should have a locking device to secure them to the vehicle.
- The handlers should wear sturdy footwear that will help to prevent slipping.
- Position the loading vehicle so that the ramp angle is as flat as possible (the less incline to the ramp, the better). Turn the vehicle's engine off and apply its parking brake.
- When going up ramps, stand in the normal operating position and push the tiller ahead of you. Have a person at each side to turn the wheels.
- When going down ramps, walk backward with the tiller following you. Keep alert for any obstacles behind you. Position a person at each wheel to control the speed of the tiller. Never go down ramps tiller-first, as the tiller could tip forward.
- Place wooden blocks on the downhill side of the wheels if you need to stop the tiller from rolling down the ramp. Also, use the blocks to temporarily keep the tiller in place on the ramps (if necessary), and to chock the wheels in place after the tiller is in the vehicle.
- After loading the tiller, prevent it from rolling by engaging the wheels in the WHEEL DRIVE position. Chock the wheels with blocks and securely tie the tiller down.



# **ATTENTION NEW PRODUCT OWNER:**



**Complete the attached registration card and return today to receive these 3 important benefits:**

## **CONFIRM YOUR WARRANTY:**

Your prompt product registration confirms your right to the protection available under the terms and conditions of your Troy-Bilt warranty.

## **PROTECT YOUR PRODUCT:**

We will keep the model number and date of purchase of your new Troy-Bilt product on file to help you refer to this information when necessary.

## **PROTECT YOUR PURCHASE:**

Your registration may serve as your proof of purchase in the case of insurance loss such as theft, fire, or flood.

**REGISTER ONLINE AT:  
WWW.TROYBILT.COM**

**THANK YOU FOR PURCHASING**



Please fill-out and return this card within 10 days!



014 A

1 First name: \_\_\_\_\_ Initial: \_\_\_\_\_ Last name: \_\_\_\_\_
Address: (number and street) \_\_\_\_\_ Apt #: \_\_\_\_\_
City: \_\_\_\_\_ State: \_\_\_\_\_ Zip code: \_\_\_\_\_

2 Phone #: \_\_\_\_\_
3 E-mail address: (EXAMPLE: yourname@yourhost.com) \_\_\_\_\_

TRB1A

- 1. Yes! I want to receive offers or communications from Troy-Bilt via e-mail.
2. Yes! I want to receive offers or communications that may interest me from other companies via e-mail. I understand this e-mail address may be shared with and/or combined with information from other sources.

4 Date of purchase: \_\_\_\_\_
5 See Operator's Manual for location of model and serial numbers.
A. Model number: \_\_\_\_\_
B. Serial number: \_\_\_\_\_

15 How large is your property?
1. Under 1 acre
2. 1 to 2 acres
3. 2 to 5 acres
4. Over 5 acres

16 Your gender: 1. Male 2. Female
17 Your marital status: 1. Married 2. Single

6 How did you learn about this product? (Check all that apply)
1. Advertisement
2. Friend/family
3. Word of mouth
4. Review in a magazine/newspaper
5. In-store display
6. Direct mail
7. Internet/website
8. Salesperson
9. Other

18 Date of your birth: \_\_\_\_\_
19 For your primary residence, do you:
1. Own 2. Rent

7 What three (3) factors most influenced your selection of this product? (Check up to three)
1. Recommendation of friend/relative
2. Brand reputation
3. In-store display
4. Good price/value
5. Retailer reputation
6. Newspaper advertisement
7. Review in magazine or newspaper
8. Television advertisement
9. Prior experience with brand
10. Salesperson recommendation/demonstration
11. Special offer/discount/rebate
12. Other

20 Including yourself, what is the total number of people living in your household?
(Examples: 01, 02, 03, 04, ...)

21 Date of birth (month/year) of the other adults and children in your household:
Male Female Male Female
1. 2. 1. 2.
Month Year Month Year

8 What three (3) features most influenced your purchase of this product? (Check up to three)
1. Horsepower
2. Warranty
3. Ease of starting
4. Cutting/cleaning/billing width
5. Attachments/accessories
6. Engine brand
7. Transmission/drive system
8. Bag/mulch/discharge versatility
9. Style/design/color
10. Other

22 Which best describes your family income?
1. Under \$15,000
2. \$15,000-\$24,999
3. \$25,000-\$34,999
4. \$35,000-\$49,999
5. \$50,000-\$74,999
6. \$75,000-\$99,999
7. \$100,000-\$124,999
8. \$125,000-\$149,999
9. \$150,000-\$174,999
10. \$175,000-\$199,999
11. \$200,000-\$249,999
12. \$250,000 or over

9 What retail outlet(s) did you shop before buying this product? (Check all that apply)
1. Independent dealer
2. Home improvement center
3. Hardware store
4. Discount store
5. Farm/ranch store
6. Wholesale club
7. Department store
8. Online
9. Other

23 Education: (Please check which category applies to you)
1. Some high school
2. Completed high school
3. College degree
4. Graduate degree

10 Before buying this unit, how long were you looking for this product?
1. Less than a month
2. 1 to 3 months
3. 3 to 6 months
4. Over 6 months

24 In the last six (6) months has anyone in your household purchased any of the following items through the mail and/or over the internet?
A. Mail B. Internet
1. Books/magazines
2. Children's products
3. Clothes
4. Insurance/financial products
5. Music/video/DVD
6. Travel
7. Other

11 What other brands did you consider before purchasing this product? (Check all that apply)
1. Ariens
2. Craftsman
3. Cub Cadet
4. Honda
5. John Deere
6. Lawn-Boy
7. Murray
8. Scotts
9. Simplicity
10. Snapper
11. Toro
12. Yard Machines
13. Yard-Man
14. Other

12 Does this product replace a similar product?
1. Yes
2. No

25 I use these credit cards:
1. American Express
2. Gas/Retail
3. Master Card
4. Visa
5. Other
6. Do not have credit cards

13 If yes, how old was the product you replaced?
1. Less than 3 years
2. 3 years old
3. 4 years old
4. 5 years old
5. 6 years old
6. 7 years old
7. 8 years old
8. 9 years old
9. 10 years old
10. More than 10 years old

14 What types of outdoor power equipment do you currently own or plan to buy within the next 3 years? (Check all that apply)
A. Own B. Plan to buy
1. Walk-behind lawnmower
2. Lawn/garden tractor
3. Tiller
4. Snowthrower
5. Air sweeper/blower
6. Chainsaw
7. Trimmer
8. Edger
9. Chipper/shredder/vacuum
10. Log splitter
11. High pressure washer
12. Generator
13. Utility vehicle
14. Compact utility tractor (18-45 hp)
15. Other

26 Someone in my home participates in the following activities: (Check all that apply)
1. Automotive work
2. Bible/devotional
3. Boating/sailing
4. Camping/hiking
5. Casino gambling
6. Contribute to charitable causes
7. Crafts
8. Cultural art/events
9. Cycling
10. Do-it-yourself
11. Enter sweepstakes/contests
12. Fishing
13. Fitness/exercise/jogging
14. Gardening
15. Golf
16. Gourmet cooking/food/wines
17. Grandchildren
18. Home decorating
19. Hunting/shooting
20. Investments (mutual funds, IRAs)
21. Investments (stocks & bonds)
22. Movie watching
23. Own a cat
24. Own a dog
25. Personal computing/Internet
26. Photography
27. Read books
28. Sewing
29. Self improvement
30. Soccer
31. Tennis
32. Travel-foreign
33. Travel-USA
34. TV shopping
35. Videos/natural foods
36. Watch sports on TV

Thank you! We appreciate your responses to this questionnaire. The information you choose to share with us will be used by us and our marketing partners to offer you product information and other communications that may interest you. If you prefer not to be contacted about these special offers, please check box D.

DETACH THIS PANEL ALONG DOTTED LINE.

**⚠ WARNING**

Before inspecting, cleaning or servicing the machine, shut off engine, wait for all moving parts to come to a complete stop, disconnect spark plug wire and move wire away from spark plug. Remove ignition key on electric start models.

Failure to follow these instructions can result in serious personal injury or property damage.

**MAINTENANCE SCHEDULE**

PROCEDURE	NOTES
Check motor oil level	2, 3
Clean engine	2, 7
Check drive belt tension	1, 4
Check nuts and bolts	1, 4
Change motor oil	4, 6, 9
Lubricate tiller	4
Service engine air cleaner system	7
Check gear oil level in transmission	1, 5
Check tines for wear	5
Check air pressure in tires (if unit has pneumatic tires)	5
Service spark plug	7

**NOTES**

- 1 - Check after first 2 hours of break-in operation.
- 2 - Before each use.
- 3 - Every 5 operating hours.
- 4 - Every 10 operating hours.
- 5 - Every 30 operating hours.
- 6 - Change more frequently in dusty or dirty conditions.
- 7 - See Engine Owner's Manual for service recommendations.
- 8 - Whichever time interval occurs first.
- 9 - Change after first 2 hours of break-in operation.

**TILLER LUBRICATION**

After every 10 operating hours, oil or grease the lubrication points shown in Figure 5-1 and described below.

Use clean lubricating oil (#30 weight motor oil is suitable) and clean general purpose grease (grease containing a metal lubricant is preferred, if available).

- Remove the wheels, clean the wheel shaft (A, Fig. 5-1) and apply a thin coating of grease to the wheel shaft.
- Grease the back, front and sides of the depth regulator lever (B, Fig. 5-1).
- Remove the tines and clean the tine shaft (C, Fig. 5-1). Use a file or sandpaper to gently remove any rust, burrs or rough spots (especially around holes in shaft). Apply grease to ends of shaft before installing tines.
- Oil the threads on the handlebar height adjustment screws and the handlebar attaching screws (D, Fig. 5-1).

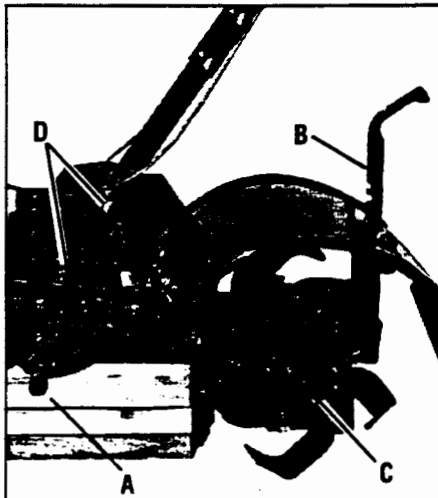

Figure 5-1

**CHECK FOR OIL LEAKS**

Before each use, check the tiller for signs of an oil leak – usually a dirty, oily accumulation either on the unit or on the floor.

A little seepage around a cover or an oil seal is usually not a cause for alarm. However, if the oil drips overnight, then immediate attention is needed. *Ignoring an oil leak can result in severe transmission damage!*

If a cover is leaking, check for loose screws. If the screws are tight, a new gasket or oil seal may be required.

If the leak is from around a shaft and oil seal, the oil seal probably needs to be replaced. See your authorized dealer or contact the factory for service or advice.

**IMPORTANT:** Never operate the tiller if the transmission is low on oil. Check the oil level after every 30 hours of operation and whenever there is any oil leakage.

**CHECK HARDWARE**

Check for loose or missing hardware after every 10 operating hours and tighten or replace (as needed) before reusing tiller

Be sure to check the screws underneath the tiller hood that secure the transmission cover and the Depth Regulator Lever to the transmission.

**CHECK TIRE PRESSURE (Models with pneumatic tires)**

Check the air pressure in both tires. The air pressure should be between 15-20 PSI (pounds per square inch).

Keep both tires equally inflated to help prevent machine from pulling to one side.

**TRANSMISSION GEAR OIL SERVICE**

Check the transmission gear oil level after every 30 hours of operation or whenever you notice any oil leak. Operating the tiller when the transmission is low on oil can result in severe damage.

**A. To Check the Transmission Gear Oil Level:**

1. Check the gear oil level when the transmission is cool. Gear oil will expand in warm operating temperatures and this expansion will provide an incorrect oil level reading.
2. With the tiller on level ground, pull the Depth Regulator Lever all the way up.
3. Remove the oil fill plug (A, Fig. 5-2) from the transmission housing and look inside the oil fill hole to locate the main drive shaft situated below the hole.

**WARNING**



Before inspecting, cleaning or servicing the machine, shut off engine, wait for all moving parts to come to a complete stop, disconnect spark plug wire and move wire away from spark plug. Failure to follow these instructions can result in serious personal injury or property damage.

4. The gear oil level is correct if the gear oil is approximately halfway up the side of the main drive shaft.

5. If the gear oil level is low, add gear oil as described next. If the gear oil level is okay, securely replace the oil fill plug.

**IMPORTANT:** Do not operate the tiller if the gear oil level is low. Doing so will result in severe damage to the transmission components.

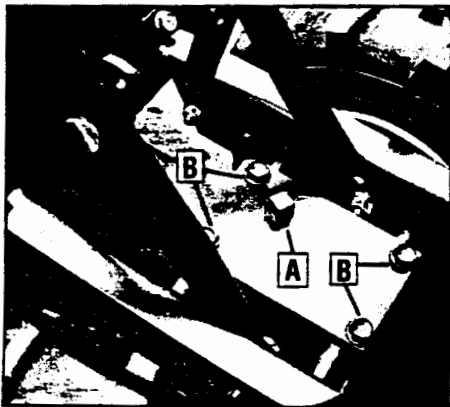

Figure 5-2: Remove oil fill plug (A) to check gear oil level and to add gear oil. Remove four cover screws (B) to drain gear oil.

6. If adding only a few ounces of gear oil, use API rated GL-4 or GL-5 gear oil having a viscosity of SAE 140, SAE 85W-140 or SAE 80W-90. If refilling an empty transmission, use only GL-4 gear oil having a viscosity of SAE 85W-140 or SAE 140.

**IMPORTANT:** Do not use automatic transmission fluid or motor oil in the transmission.

7. While checking frequently to avoid overfilling, slowly add gear oil into the oil fill hole until it reaches the halfway point on the drive shaft.

8. Securely replace the oil fill plug.

**B. To Drain the Transmission Gear Oil:**

The transmission gear oil does not need to be changed unless it has been contaminated with dirt, sand or metal particles.

1. Drain gasoline from the fuel tank or run the engine until the fuel tank is empty. See "DANGER" statement below.

**DANGER**

Gasoline is highly flammable and its vapors are explosive. Follow these safety practices to prevent personal injury or property damage from fire or explosion.

- Allow the engine and muffler to cool for at least two minutes before draining the tiller's gasoline tank.
- Do not allow open flames, sparks, matches or smoking in the area.
- Wipe away spills and push tiller away from spilled fuel.
- Use only an approved fuel container and store it safely out of the reach of children.
- Do not store gasoline in an area where its vapors could reach an open flame or spark, or where ignition sources are present (such as hot water and space heaters, furnaces, clothes dryers, stoves, electric motors, etc.)

2. Drain the oil from the engine.
3. Remove four screws (B, Figure 5-2) and remove transmission cover and gasket.
4. Remove the left-side wheel.
5. Tilt the left-side wheel shaft into a drain pan and allow the gear oil to drain through the top of the transmission.
6. Reinstall the wheel.
7. Install a new gasket (do not reuse old gasket) and reinstall the transmission cover.
8. Refill the transmission using GL-4 gear oil (SAE 85W-140 or SAE 140).
9. Refill the engine with motor oil and replenish the fuel tank with gasoline.

**BOLO TINES**

The bolo tines will wear with use and should be inspected at the beginning of each tilling season and after every 30 operating hours. The tines can be replaced either individually or as a complete set. See the Parts List pages for tine identification and part numbers.

**A. Tine Inspection:**

With use, the tines will become shorter, narrower and pointed. Badly worn tines will result in a loss of tilling depth, and reduced effectiveness when chopping up and turning under organic matter.

**B. Removing/Installing a Single Tine:**

1. With the engine shut off and the spark plug wire disconnected, remove the two screws (A, Figure 5-3), lockwashers (E) and nuts (B) that attach a single tine to a tine holder. If needed, use penetrating oil on the nuts.

2. When installing a single tine, be sure to position it so that its *cutting edge (sharp)* will enter the soil first as the tiller moves forward.

**C. Removing/Installing a Tine Assembly:**

1. A tine assembly consists of eight tines mounted on a tine holder.
2. If removing both tine assemblies, mark them "left" and "right" before removal. Remove the screw (C, Figure 5-3), lock washer (E) and locknut (D) that secure the tine assembly to the tine shaft. If necessary, use a rubber mallet to tap the tine assembly outward off the shaft.
3. Before reinstalling the tine assembly, inspect the tine shaft for rust, rough spots or burrs. Lightly file or sand, as needed. Apply a thin coat of grease to the shaft.
4. Install each tine assembly so that the *cutting (sharp) edge of the tines* will enter the soil first when the tiller moves forward. Secure the tine assembly to the tine shaft using the screw and locknut previously removed.



**WARNING**

Before inspecting, cleaning or servicing the machine, shut off engine, wait for all moving parts to come to a complete stop, disconnect spark plug wire and move wire away from spark plug. Failure to follow these instructions can result in serious personal injury or property damage.

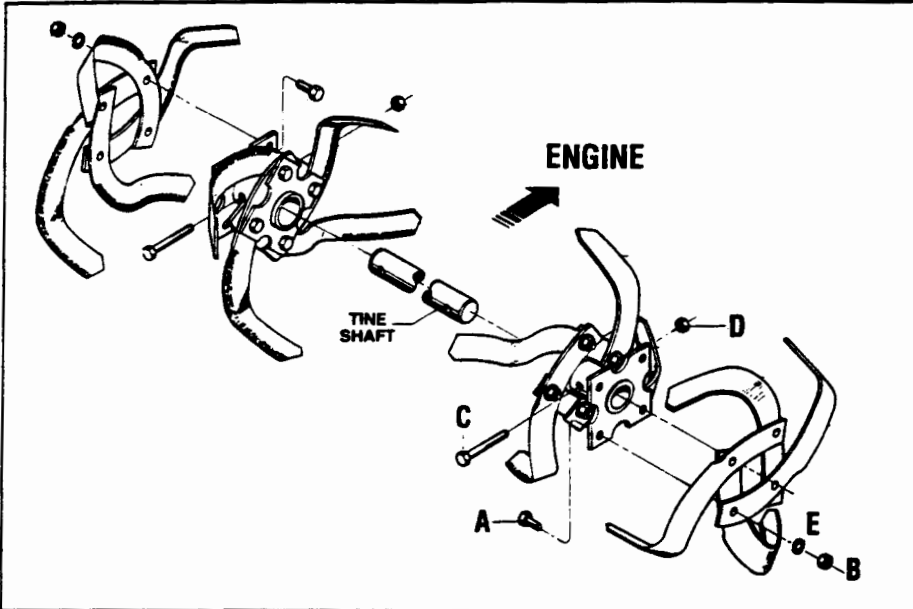

Figure 5-3: Install tines so that cutting edge of tines enter soil first when tiller moves forward.

- c. Unhook the top of the spring from the Forward Clutch Bail.
- d. Use pliers to prevent the adjuster (B) from turning and turn the slotted screw located inside the spring clockwise (viewed from operator's position) to increase tension on the spring. Turn the screw counter-clockwise to decrease tension. Once adjusted, reattach the spring to the Forward Clutch Bail.
- e. Repeat Steps 2 and 3 to re-measure the length of the spring. When the second measurement is between 1/16" -to- 3/16" longer than the first measurement, retighten the hex nut (C) against the top of the adjuster (B).

**CHECKING AND ADJUSTING FORWARD DRIVE BELT TENSION**

It is important to maintain correct tension on the forward drive belt. A loose belt will cause the tines and wheels to slow down – or stop completely – even though the engine is running at full speed. A too tight belt can result in unintentional tine movement when the clutch bail is in the Neutral (released) position.

- Check belt tension after the first two hours of break-in operation and after every 10 operating hours.
- At the end of each tilling season, check the belt for cracks, cuts or frayed edges and replace it as soon as possible.

**To Check Forward Belt Tension:**

1. Stop engine, wait for all parts to stop moving and disconnect spark plug wire.
2. With the Forward Clutch Bail in an open (released) position, measure and note the overall length of the cable spring (A, Figure 5-4) by measuring from the outermost coil to the outermost coil.
3. Squeeze the Forward Clutch Bail against the handlebar (see Figure 5-4) and re-measure the length of the coils. The belt tension is correct if this second

measurement is between 1/16" -to- 3/16" longer than the first measurement.

4. If the spring is too short (less than 1/16"), the tension is too loose. If the spring is too long (more than 3/16"), the tension is too tight.
5. To adjust the length of the spring:
  - a. Release the Forward Clutch Bail.
  - b. Unthread the hex nut (C, Figure 5-4) about halfway up the adjustment screw (D).

**Replacement Belt Information**

If the drive belt needs to be replaced, see your local authorized dealer or refer to the Parts List for ordering information. Use only a factory-authorized belt as an "over-the-counter" belt may not perform satisfactorily. The procedure requires average mechanical ability and commonly available tools.

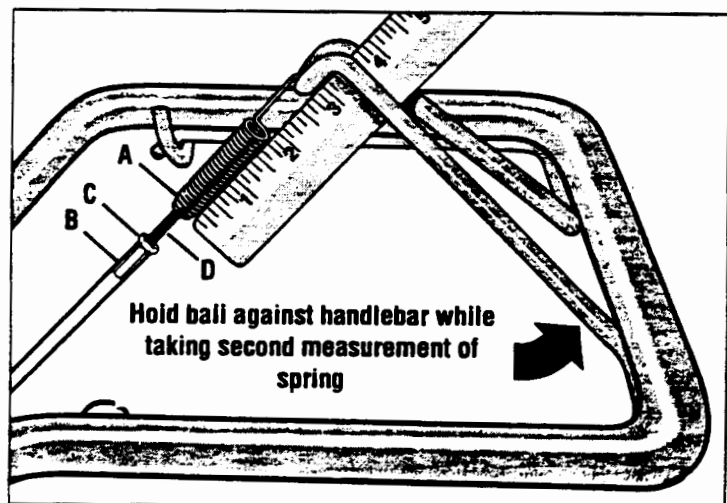

Figure 5-4: To check forward belt tension, take two measurements of the overall length of the coils in the spring – first with the clutch ball open, then with the clutch ball closed against the handlebar.

**WARNING**

Before inspecting, cleaning or servicing the machine, shut off engine, wait for all moving parts to come to a complete stop, disconnect spark plug wire and move wire away from spark plug. Failure to follow these instructions can result in serious personal injury or property damage.

## FORWARD CLUTCH BAIL ADJUSTMENT

If the Forward Clutch Bail does not function properly, first check that the forward drive belt is adjusted properly (see *Checking and Adjusting Forward Drive Belt Tension*). If this fails to correct the problem, contact the factory Technical Service Department or your authorized dealer for service advice.

## CHECKING AND ADJUSTING REVERSE DRIVE BELT TENSION (Models 634F/634B only)

It is important to maintain correct tension on the reverse drive belt. A loose belt will cause the tines and wheels to slow down – or stop completely – even though the engine is running at full speed.

When checking belt tension, also check the belt for cracks, cuts or frayed edges and replace it as soon as possible.

- Check belt tension after the first two hours of break-in operation and after every 10 operating hours.

### To Check Reverse Belt Tension:

1. Stop engine, wait for all parts to stop moving and disconnect spark plug wire.
2. Remove screw in plastic belt cover and slide belt cover (which is attached to forward clutch cable) out of the way.
3. Have an assistant pull the Reverse Clutch Control knob all the way out and hold it in that position. Measure the length of the cable wire between the end of the threaded cable adjuster (A, Figure 5-5) and the end of the z-fitting (B) to which the cable wire is attached.
4. The belt tension is ideal if the cable wire length measures between 1/8" to 1/4". If it is less than 1/8" (and if there is no reverse action when the tiller is running), then make the following adjustments.  
NOTE: If the length is more than 1/4", no adjustment is needed—as long as the reverse action functions properly.

5. Release the Reverse Clutch Control knob and then unthread the inner jam nut (C, Figure 5-6) one to two turns. Pull the threaded cable adjuster (A, Figure 5-6) to the left until the inner jam nut (C) touches the bracket.

6. Prevent the inner jam nut (C) from turning and tighten the outer jam nut (D) against the bracket. Prevent the outer jam nut (D) from turning and tighten the inner jam nut (C) against the bracket.

7. Measure the gap by repeating Step 3. Readjust as needed by repeating Steps 5 and 6.

8. Reinstall the belt cover.

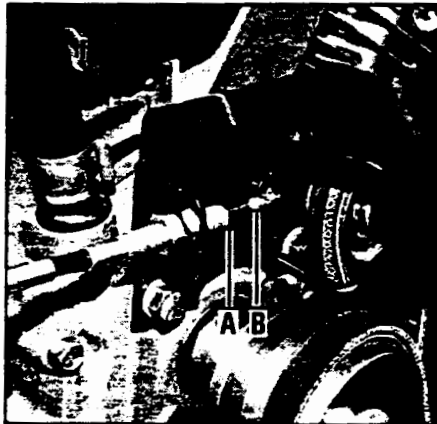

Figure 5-5: Measure cable wire length to check for correct reverse belt tension.

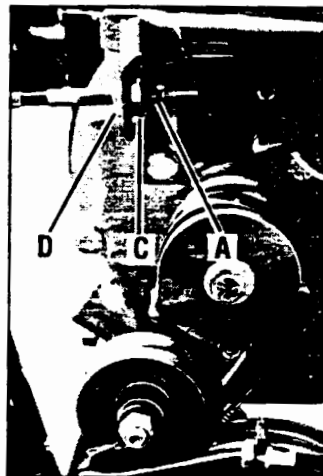

Figure 5-6: Move threaded adjuster (A) to left to increase belt tension.

### Replacement Belt Information

If the drive belt needs to be replaced, see your local authorized dealer or refer to the Parts List for ordering information. Use only a factory-authorized belt as an "over-the-counter" belt may not perform satisfactorily. The procedure requires average mechanical ability and commonly available tools.

## ENGINE CLEANING

Keeping the engine clean will help to ensure smooth operation and prevent damage from overheating. Refer to the Engine Owner's Manual for engine cleaning service intervals and instructions. Be sure that the muffler is cool before servicing the engine.

## AIR CLEANER SERVICE

The air cleaner filters dirt and dust out of the air before it enters the carburetor. Operating the engine with a dirty, clogged air filter can cause poor performance and damage to the engine. Never operate the engine without the air cleaner installed. Inspect and service the air cleaner more often if operating in very dusty or dirty conditions. Refer to the Engine Owner's Manual for air cleaner service intervals and instructions.

## ENGINE OIL SERVICE

Check the engine oil level before each use and after every 5 hours of continuous operation. Running the engine when it is low on oil will quickly ruin the engine.

It is recommended that you change the motor oil after every 10 hours of operation and even sooner when operating in extremely dirty or dusty conditions. Refer to the Engine Owner's Manual for detailed service instructions.

### A. To Check the Engine Oil Level:

1. Park the tiller on a level area and shut off the engine.
2. Level the engine (use the Depth Regulator Lever to adjust the engine angle).

**WARNING**

Before inspecting, cleaning or servicing the machine, shut off engine, wait for all moving parts to come to a complete stop, disconnect spark plug wire and move wire away from spark plug. Failure to follow these instructions can result in serious personal injury or property damage.

3. Clean around the oil dipstick or oil fill tube (whichever applies) to prevent dirt from falling into the crankcase.
4. On engines with an oil fill tube, remove the fill cap and add oil (if required) until it reaches the top of the fill tube. Reinstall the fill cap.
5. On engines with a dipstick, remove it and wipe it clean. Reinsert the dipstick, tighten it securely, and remove it. Add oil as needed to bring the level up to the FULL mark. Wipe dipstick clean each time oil level is checked. Do not overfill. Tighten dipstick securely.

**B. To Change the Engine Oil:**

Change the engine oil as instructed in the Engine Owner's Manual.

**SPARK PLUG SERVICE**

Inspect and clean or replace the spark plug after every 100 operating hours or annually. Refer to the Engine Owner's Manual for spark plug service instructions.

In some areas, local law requires using resistor spark plugs to suppress ignition signals. If the engine was originally equipped with a resistor spark plug, use the same type for replacement.

**SPARK ARRESTER SCREEN SERVICE**

If the engine muffler is equipped with a spark arrester screen, remove and clean it according to the service intervals and instructions in the Engine Owner's Manual.

**THROTTLE LEVER ADJUSTMENT**

If the engine does not respond to various throttle lever settings, refer to the Engine Owner's Manual for service information or contact your local authorized engine dealer.

**WARNING**

**Operators shall not tamper with the engine governor settings on the machine; the governor controls the maximum safe operating speed to protect the engine and all moving parts from damage caused by overspeed. Authorized service shall be sought if a problem exists.**

**CARBURETOR/GOVERNOR CONTROL ADJUSTMENTS**

The carburetor was adjusted at the factory for best operating speed. Refer to the Engine Owner's Manual for any adjustment information or see your authorized engine dealer.

The governor controls the maximum safe operating speed and protects the engine and all moving parts from damage caused by overspeeding. Do not tamper with the engine governor settings.

**OFF SEASON STORAGE**

When the tiller won't be used for an extended period, prepare it for storage as follows:

1. Clean the tiller and engine.
2. Do routine tiller lubrication and check for loose parts and hardware.
3. Protect the engine and perform recommended engine maintenance by following the storage instructions found in the Engine Owner's Manual. Be sure to protect the fuel lines, carburetor and fuel tank from gum deposits by removing fuel or by treating fuel with a fuel stabilizer (follow engine manufacturer's recommendations).
4. Store unit in a clean, dry area.
5. Never store the tiller with fuel in the fuel tank in an enclosed area where gas fumes could reach an open flame or spark, or where ignition sources are present (space heaters, hot water heaters, furnaces, etc.).



 <p><b>WARNING</b></p>	<p>Before inspecting, cleaning or servicing the machine, shut off engine, wait for all moving parts to come to a complete stop, disconnect spark plug wire and move wire away from spark plug. Failure to follow these instructions can result in serious personal injury or property damage.</p>
---	---

### TROUBLESHOOTING

Before performing any troubleshooting procedures, refer to the appropriate safety, operating or maintenance instructions in this Manual or in the Engine Owner's Manual. Contact your authorized engine service dealer for engine service. Contact your authorized tiller dealer or the factory for all other service problems.

PROBLEM	POSSIBLE CAUSE	CORRECTION
Engine does not start.	<ol style="list-style-type: none"> <li>1. Spark plug wire disconnected.</li> <li>2. Engine Throttle Control Lever incorrectly set.</li> <li>3. Fuel tank empty.</li> <li>4. Choke control (if so equipped) in incorrect position.</li> <li>5. Stale gasoline.</li> <li>6. Dirty air filter(s).</li> <li>7. Defective or incorrectly gapped spark plug.</li> <li>8. Carburetor out of adjustment.</li> <li>9. Misadjusted throttle control.</li> <li>10. Dirt or water in fuel tank.</li> </ol>	<ol style="list-style-type: none"> <li>1. Reconnect wire.</li> <li>2. Put lever in START position.</li> <li>3. Add fuel.</li> <li>4. See Engine Owner's Manual.</li> <li>5. Drain fuel and add fresh fuel.</li> <li>6. Clean or replace filter(s).</li> <li>7. Inspect spark plug.</li> <li>8. See Engine Service Dealer.</li> <li>9. See Engine Service Dealer.</li> <li>10. See Engine Service Dealer.</li> </ol>
Engine runs poorly.	<ol style="list-style-type: none"> <li>1. Defective or incorrectly gapped spark plug.</li> <li>2. Dirty air filter(s).</li> <li>3. Carburetor out of adjustment.</li> <li>4. Stale gasoline.</li> <li>5. Dirt or water in fuel tank.</li> <li>6. Engine cooling system clogged.</li> </ol>	<ol style="list-style-type: none"> <li>1. Inspect spark plug (see Engine Owner's Manual).</li> <li>2. Clean or replace (see Engine Owner's Manual).</li> <li>3. See Engine Service Dealer.</li> <li>4. Replace with fresh gasoline.</li> <li>5. See Engine Service Dealer.</li> <li>6. Clean air cooling system (see Engine Owner's Manual).</li> </ol>
Engine overheats.	<ol style="list-style-type: none"> <li>1. Engine cooling system clogged.</li> <li>2. Carburetor out of adjustment.</li> <li>3. Oil level is low.</li> </ol>	<ol style="list-style-type: none"> <li>1. Clean air cooling area (see Engine Owner's Manual).</li> <li>2. See Engine Service Dealer.</li> <li>3. Check oil level (see Engine Owner's Manual).</li> </ol>
Engine does not shut off.	<ol style="list-style-type: none"> <li>1. Misadjusted throttle control or ignition switch.</li> </ol>	<ol style="list-style-type: none"> <li>1. See Engine Owner's Manual or Engine Service Dealer.</li> </ol>
Wheels and Tines will not turn.	<ol style="list-style-type: none"> <li>1. Improper use of controls.</li> <li>2. Worn, broken, or misadjusted drive belt(s).</li> <li>3. Internal transmission wear or damage.</li> <li>4. Bolt loose in transmission pulley.</li> </ol>	<ol style="list-style-type: none"> <li>1. Review Sections 3 and 4.</li> <li>2. See "Checking Drive Belt Tension," Section 5.</li> <li>3. Contact local dealer or the factory.</li> <li>4. Tighten bolt.</li> </ol>
Tines turn, but wheels don't.	<ol style="list-style-type: none"> <li>1. Wheel Drive Pins not in WHEEL DRIVE.</li> <li>2. Bolt loose in transmission pulley.</li> <li>3. Internal transmission wear or damage.</li> </ol>	<ol style="list-style-type: none"> <li>1. See "Wheel Drive Pins" in Section 3.</li> <li>2. Tighten bolt.</li> <li>3. Contact local Dealer or the Factory.</li> </ol>
Wheels Turn, but Tines Don't.	<ol style="list-style-type: none"> <li>1. Tine holder mounting hardware missing.</li> <li>2. Bolt loose in transmission pulley.</li> <li>3. Internal transmission wear or damage.</li> </ol>	<ol style="list-style-type: none"> <li>1. Replace hardware.</li> <li>2. Tighten bolt.</li> <li>3. Contact local Dealer or the Factory.</li> </ol>
Poor tilling performance.	<ol style="list-style-type: none"> <li>1. Worn tines.</li> <li>2. Improper Depth Regulator setting.</li> <li>3. Incorrect throttle setting.</li> <li>4. Forward Drive Belt slipping.</li> </ol>	<ol style="list-style-type: none"> <li>1. See "Bolo Tines" (Section 5).</li> <li>2. See "Tilling Tips &amp; Techniques," Section 4.</li> <li>3. See Section 4.</li> <li>4. See "Checking Forward Drive Belt Tension," Section 5.</li> </ol>

### TILLER ATTACHMENTS

The attachments listed below are available for your tiller. The information is the most current at the time this manual was printed. Contact your authorized dealer or the factory for current information.

**BUMPER** – The tubular steel bumper surrounds the engine to protect the air cleaner, starter assembly and fuel tank from damage.

**OEM-290-256 fits Tuffy, OEM-290-254 fit Bronco**

**FRAME WEIGHTS** – Solid steel weights attach to the sides of the tiller frame to provide added traction to the wheels.

**OEM-290-265 fits Tuffy, Bronco & Super Bronco**

# TROY-BILT TILLER LIFETIME LIMITED WARRANTY

## WHAT PRODUCT IS COVERED

All Troy-Bilt branded rear tine walk-behind tillers with gear drive transmissions. This warranty begins on the date of purchase and is warranted by Troy-Bilt LLC for the life of the tiller, to the original purchaser only.

## WHAT IS COVERED BY THIS WARRANTY

Troy-Bilt LLC will, at its option, repair or replace any part found to be defective in material or workmanship without charge for parts and labor.

This limited lifetime warranty also applies to non-powered attachments and accessories. Powered attachments and accessories are warranted separately by their manufacturers. Refer to the applicable manufacturer's warranty on these items for terms and conditions.

## WHAT IS NOT COVERED BY THIS WARRANTY

This warranty does not apply to parts that have been damaged by accident, alteration, misuse, abuse, neglect, improper maintenance, vandalism, theft, fire, water, or damage because of peril or other natural disaster.

The following items are not covered after the first year of this residential use limited warranty: belts, batteries, bushings, seals, tines, tires, wheels, paint, appearance items, and similar items that are normally replaced through periodic maintenance.

Charges for pick-up, delivery, and service calls are not covered by this warranty.

Service completed by someone other than an authorized service dealer is not covered by this warranty.

Parts that are not genuine Troy-Bilt LLC service parts are not covered by this warranty.

The engine is warranted separately by the engine manufacturer. Refer to the engine manufacturer's warranty for terms and conditions.

## LIMITED COMMERCIAL USE WARRANTY

If used for commercial, institutional, industrial, rental, or demonstrator purposes, the warranty on the tiller is limited in duration to 90 days from the date of purchase.

This warranty does not apply to parts that have been damaged by accident, alteration, misuse, abuse, neglect, improper maintenance, vandalism, theft, fire, water, or damage because of peril or other natural disaster.

## HOW TO OBTAIN SERVICE

Warranty service is available, with proof of purchase, through your local authorized service dealer. To locate a dealer in your area, consult your Yellow Pages, or contact Troy-Bilt LLC at P.O. Box 361131, Cleveland, Ohio 44136-0019, 1-866-840-6483, or log on to our Web site at [www.troybilt.com](http://www.troybilt.com).

**The provisions set forth in this warranty provide the sole and exclusive remedy arising from the sale. Troy-Bilt LLC shall not be liable for any incidental or consequential damage or expense of any kind, including but not limited to cost of equipment rental, loss of profits, or costs of hiring services to perform tasks normally performed by the equipment.**

Any implied warranties, including any implied warranty of merchantability or fitness for a particular purpose, shall be limited in duration to the period of ownership by the original purchaser (and a maximum of 90 days from the date of sale if the tiller is purchased for commercial or other non-residential use).

Some states do not allow the exclusion or limitation of incidental or consequential damages, or limitations on how long an implied warranty lasts, so the above exclusions or limitations may not apply to you.

This limited warranty gives you specific legal rights, and you may also have other rights which vary from state to state.

*For customer assistance, contact your nearest authorized dealer, or contact us at:*

**TROY-BILT LLC, P.O. Box 361131, Cleveland, Ohio 44136-0019, 1-866-840-6483**